



# Friedhelm TRAPP GmbH

Ostring 15 - 63533 Mainhausen - Zentrale: 06182/9294-5 - Fax: 06182/9294-69 - Mail: trapp@f-trapp.de

[www.f-trapp.de](http://www.f-trapp.de)

## Handrail TGB-2005



**Applicationexample TGB-2005**



# Friedhelm TRAPP GmbH

Ostring 15 - 63533 Mainhausen - Zentrale: 06182/9294-5 - Fax: 06182/9294-69 - Mail: trapp@f-trapp.de

[www.f-trapp.de](http://www.f-trapp.de)

## Handrail TGB-2005

### Dimensioning

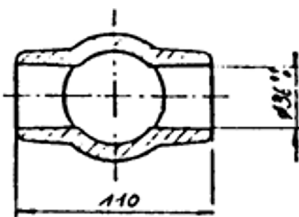
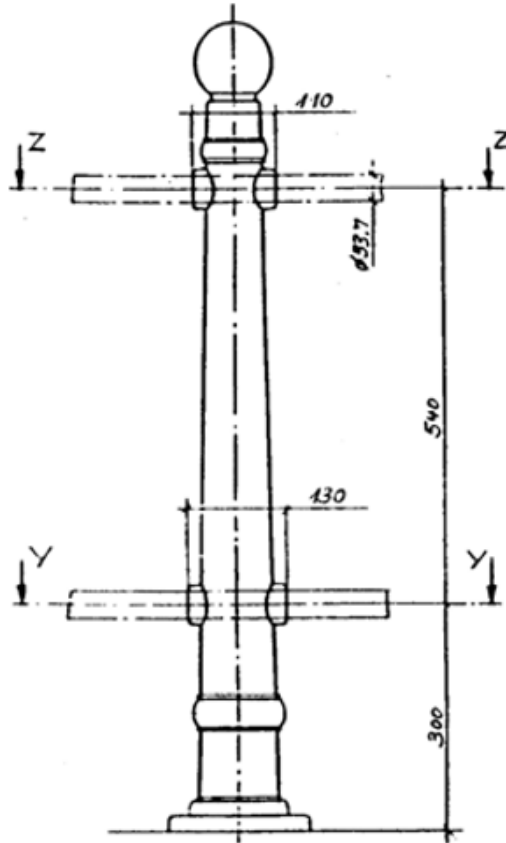

Middle post nr. 2005-4 A, section Z-Z

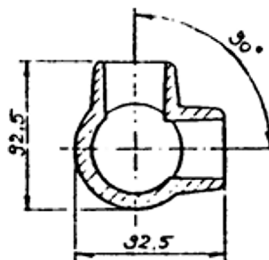

Corner posts nr. 2005-4 B, section Z-Z

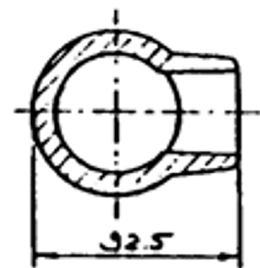

End post nr. 2005-4 C, section Z-Z

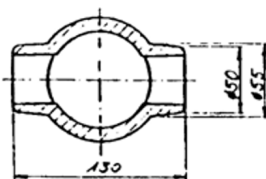

Middle post nr. 2005-4 A, section Y-Y

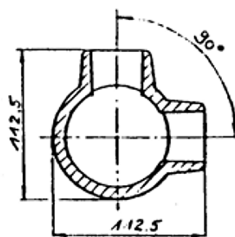

Schnitt Y-Y

Corner posts nr. 2005-4 B, section Y-Y

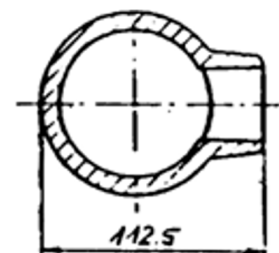

End post nr. 2005-4 C, section Y-Y



# Friedhelm TRAPP GmbH

Ostring 15 - 63533 Mainhausen - Zentrale: 06182/9294-5 - Fax: 06182/9294-69 - Mail: trapp@f-trapp.de

[www.f-trapp.de](http://www.f-trapp.de)

## Handrail TGB-2404



Bollard Nr. 2404 for demarcation of green areas

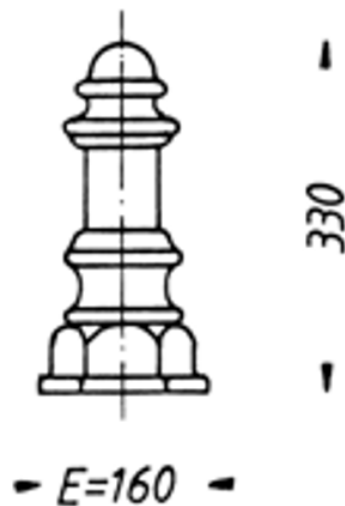

Bollard no. 2404-1 for flange connection

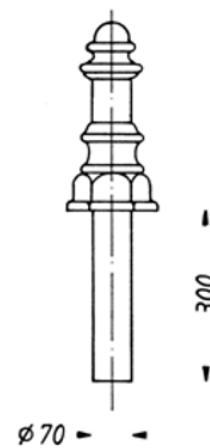

Bollard no. 2404-2 for casting in concrete



# Friedhelm TRAPP GmbH

Ostring 15 - 63533 Mainhausen - Zentrale: 06182/9294-5 - Fax: 06182/9294-69 - Mail: trapp@f-trapp.de

[www.f-trapp.de](http://www.f-trapp.de)

## Connecting pipe 5001



### Connecting pipe Nr. 5001

Delineation of green areas in connection with bollard no. 2404  
As railing in conjunction with bollard no. 2004 or no. 3002  
Also available in lengths of 1 m and 2 m

**Material:**

steel pipe, galvanized, ornamental parts and bottom sleeve made of cast aluminum

**Paint:**

2 times, top coat as desired

**attachment elements for No. 5001:**

VA screws

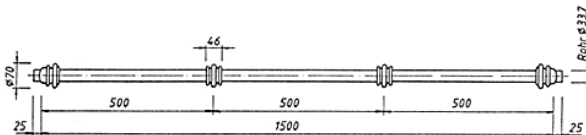



# Friedhelm TRAPP GmbH

Ostring 15 - 63533 Mainhausen - Zentrale: 06182/9294-5 - Fax: 06182/9294-69 - Mail: trapp@f-trapp.de

[www.f-trapp.de](http://www.f-trapp.de)

## Green space limitations

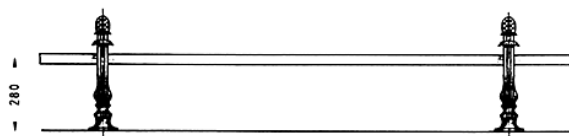

Green space limiting TGB-2101

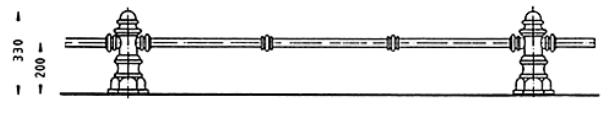

Green space limiting TGB-2404

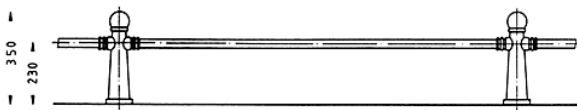

Green space limiting TGB-2505



Green space limiting TGB-3505





# Friedhelm TRAPP GmbH

Ostring 15 - 63533 Mainhausen - Zentrale: 06182/9294-5 - Fax: 06182/9294-69 - Mail: trapp@f-trapp.de

[www.f-trapp.de](http://www.f-trapp.de)

## Green space limitations

### Example



TGB-2102

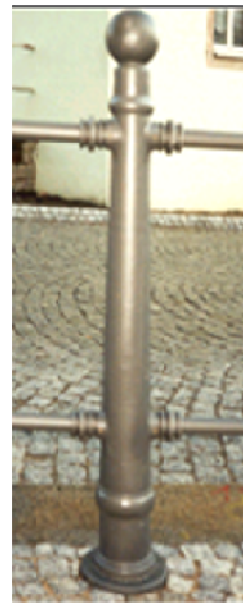

TGB-2005



TGB-3005



TGB-3006